

SALT WATER CHLORINATOR C8P

USER'S MANUAL

Ver. 1

CHLORINATOR'S INFORMATION

FILL IN THE FOLLOWING FORM WITH THE REGISTRATION DATA THAT IS ON THE SIDE LABEL OF THE UNIT YOU HAVE ACQUIRED

YOU WILL NEED THIS DATA IF YOU WISH TO CONSULT YOUR SUPPLIER OR BSV ELECTRONIC S.L.

MODEL.....
IP.....
REF.
VOLTAGE.....
NUM.

INDEX

- | | |
|--|---|
| 1. GENERAL DESCRIPTION, 3 | <u>6. SOFTWARE VERSION, 9</u> |
| 1.1 SEGURIDADES, 4 | 7. INSTALLATION, 9 |
| 1.4 Specification, 4 | 7.1 HYDRAULIC CIRCUIT, 10 |
| 2. SWIMMING POOL PREPARATION, 5 | 7.2 WIRING DIAGRAM, 11 |
| <u>3. SETTINGS, 6</u> | <u>8. MAINTENANCE, 12</u> |
| <u>4. ALARMS, 6</u> | 8.1 Cleaning the electrolytic cell, 12 |
| <u>5. RUNNIN HOURS, 8</u> | 9. WARRANTY AND SERVICE, 14 |
| 5.3 Keeping the water clean, 13 | |



WARNING

Before installing and starting up the chlorinator you have acquired, read carefully this manual. If you need any clarification or have any doubts, please contact with your distributor or BSV Electronic S.L. directly and we will be happy to help you.

1. GENERAL DESCRIPTION

First of all, thank you for choosing salt water chlorinator BS POOL with the one you will enjoy your swimming pool in perfect conditions without need to add disinfectants, chemical products,...

The BSV Electronic S.L. saline chlorinators allow you to keep the water in your pool clean and crystal-clear, without adding chemical disinfectants.

The system of saline chlorination for swimming pools, manufactures the chlorine directly in the filter installation by means of water electrolysis slightly salty. "Free chlorine" (hypochlorous acid, HOCL) is produced, which is a strong bactericide.

An important characteristic of the system is that it is reversible, that means, after oxidising the bacteria, chlorine reverts back to common salt and water. It is not necessary to add any chemical product (algaecides, cyanuric acid, etc.) which helps keeping the water unpolluted.

Slightly salt water is healthier than pure water: the skin wrinkles less and eye irritation is reduced.

The equipment is made of an electronic control unit of command and regulation and an electrolytic cell through which runs the pool water normally settled in the return of the filtration circuit.

If the chlorinator keeps working permanently, it will not be necessary to replace the water for many years, and you will collaborate with the environmental politics of water savings.



1.1 SECURITY

In order to avoid that the device operates in abnormal conditions, the control unit measures continuously the parameters and the state of the electrolysis circuit, so that if the water flow in the cell is not correct, if the cell detects a short circuit or an over-voltage, the power circuit automatically disconnects creating a luminous and acoustic alarm till the problem is solved. After a while, the device restarts automatically.

1.2 Technical characteristics

- Supply voltage: 230VAC/ 50Hz.
- Max. output power: C8P – 60W
- Max. Cell voltage: 7.5 Vcc.
- Insulation voltage according to EN 609050: 3000 Vac
- Control of chlorine production with a switched mode power supply.
- Power amp efficiency > 90%.
- Automatic Stop in case of gas accumulation in the electrolysis cell with automatic restart when the water flow is restored.
- Lack of salt warning.
- Excess of salt warning
- Automatic tension regulation in function of the salt concentration
- Chlorine level indicator.
- Current surge indicator and automatic lock of the power amp with timing automatic restart.
- Acoustic alarm
- Non volatile memory (EEPROM) with permanent data saving.
- Automatic electrode cleaning cycle, every 8 hours
- Control of the internal temperature
- Automatic restart after power supply loss.
- Working hours counter

2. POOL PREPARATION

It is necessary to add some salt to the water and ensure that the pH level is adequate. PH and salt levels have to be as follows:

WATER POOL PREPATRATION

Salt, kg/m³ ----- 2* - 6, 5

PH ----- 7,0 - 7, 6

* The device starts working from 2gr/L. Nevertheless, the chlorine production will not reach 100% until the salt level dissolved in the water is 4gr/L.

Chlorination efficiency and water quality for a healthy bath depend of the water pH, so it is important to control it regularly and adjust it when necessary. If you do not want to be pending of pH control, you can acquire one of our pH automatic controllers, shown in our catalogue, which can be included in the chlorinator.

To compute the quantity of salt needed, multiply the water volume in cubic meters by 4.5.

EXEMPLE: Swimming pool 9 m long, 4.5 m wide, 1.6 m average depth:

$9 \times 4,5 \times 1,6 = 64,8$ cubic meters

$64,8 \times 4,5 = 291,6$ kg of salt

Note: 4.5 is the amount of salt per m³.

We advise to use salt specially prepared for swimming pool chlorinators, as it is made for easy solubility. It is available in shops specialised in swimming pool products.



WARNING!

When adding salt to the water, switch off the chlorinator and run the pump for 3 to 4 hours allowing the salt to dissolve. Only when all salt is melt down the chlorinator can be started. It is advisable to add salt in 2 or 3 times. The excess of salt can overload the chlorinator which will be disconnected automatically, in that case add water to reduce the concentration.

3. SETTINGS

Two push buttons, P1 and P2, are used to set chlorine production.

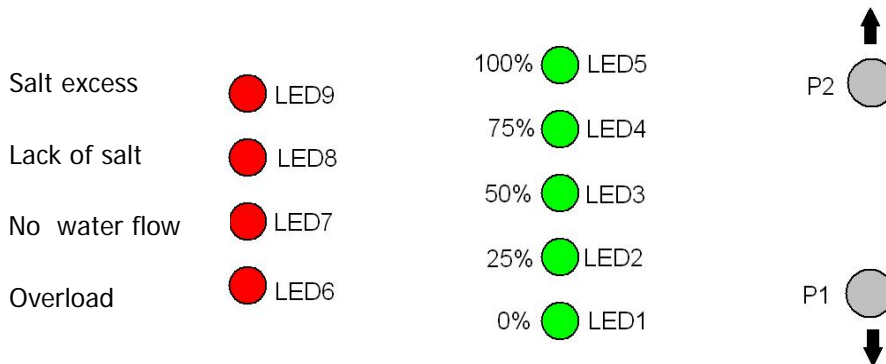

With P2 production is increased and with P1 it is decreased.

Green LEDs LED1 to LED5 show chlorine production: 0%, 25%, 50%, 75% and 100% of the maximum value.

The setting is saved even if the chlorinator is switched off.

4. MESSAGES AND ALARMS:

MESSAGES:

LED9: Indicates an Excess of salt.

- "TOO MUCH SALT":

Causes:	Action:
The cell is dirty.	Remove and clean the cell.
Too much salt in the water	No action has to be taken OR change part of the water.

LED8: Lack of salt. The chlorinator cannot reach the maximum chlorine production level.

- "LOW SALT":

Causes:	Action:
Cell dirty.	Clean the cell.
Lack of SALT into the water.	Add salt to the water otherwise it cannot reach the maximum production
The swimming pool has been filled with fresh water.	

LED 7 and acoustic alarm: LED flashes flick to show that there is gas in the electrolysis cell or that there is no water flow in the cell. Green LED´s column is blinking, showing that the equipment has switched off the cell current.

- "NO FLOW":

Causes:	Action:
Cell sensor dirty.	Remove and clean the cell. (See in the manual 8.1)
Wiring problem of the sensor.	Check the sensor wire (white wire) has continuity and it is well connected.
Too much gas in the electrolytic cell. This happens if the pump stops. The gas is hydrogen, very inflammable. There is an air bag on the cell	Purge the gas or the air accumulate in the pipe
Cell sensor is break	Replace the cell.
The most probable cause is that the pump has stopped. Once restored the water flow, the alarm rearms automatically	Restore the water flow circulation.
Other	Contact with your distributor or BSV Electronic S.L or your supplier.

NOTE: Clean the cell at least once a year as detailed in point 8.1.always before summer season.

LED6 and acoustic alarm: Flashes showing overload.

-"SHORT-CIRCUIT":

Causes:	Action:
Cell electrodes dirty.	Clean the cell as shown in "Maintenance"
Bad cell contact.	Check the sensor wire is the correct one.
There is some metallic object between the cell laminates	Turn off the equipment and take away the metallic object of the laminates.
Other	Contact with your distributor or BSV Electronic S.L or your supplier.

Lack of current indication (the green LED column flashes):

If there is not current in the cell or the current is not enough, the green LEDs column flashes.

Causes:	Action:
No water flow or overload	Restore the water flow circulation or check if there is an overload
Cell disconnected.	Connect cell.
Check that the ambient temperature does not surpass 40°C. Check that heat sink fins are in vertical position and the air flow is not obstructed.	Let rest the equipment for some minutes. Do a forced airing
The chlorinator is off during the inverting voltage direction. The process takes 5 minutes.	The chlorinator is cleaning de cell. Inverting voltage direction.
Not salt in the water	Put advised salt as per indications in point 2

5. RUNNING HOURS

To know the total time the unit has been running may be useful for maintenance purposes. Sequences of 6 digits, starting to the left.

Green LEDs show a digit from 1 to 5. If LED6 in on, add 5 to the digit. If the result is 10 (LED1 to LED6 on), the digit is 0. So digits appear as shown below:

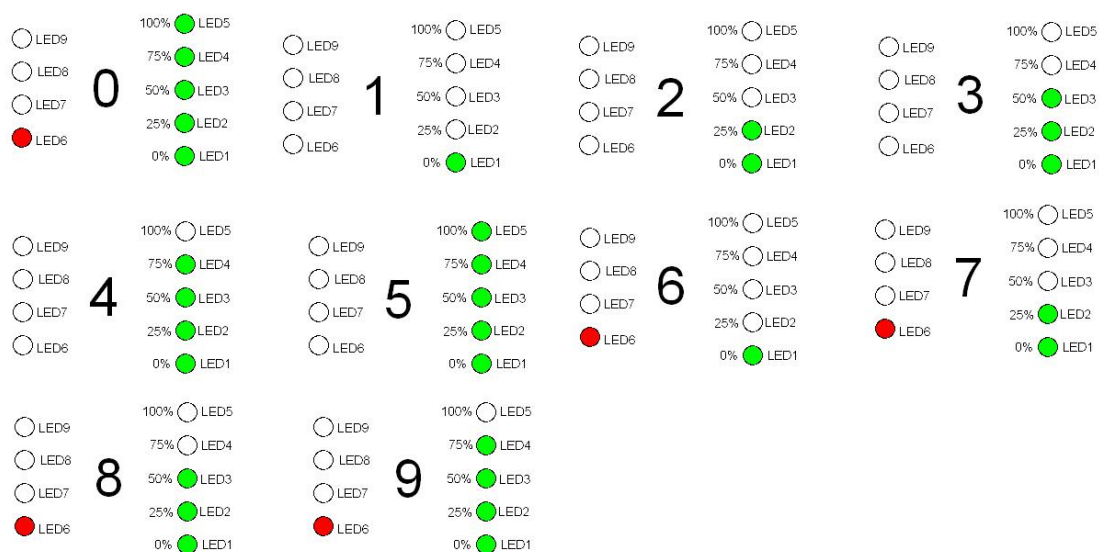

Stop the chlorinator. Switch on again keeping push button switch P1 ↓ pressed.

LED9 flashes for a while. The 1st digit is displayed. Press P1 ↓ each time you want to see the following digit. LED9 flashes when last digit has been shown.

As an example, if digits were "000345", the unit has worked for 345 hours.

6. SOFTWARE VERSION

To check the software version switch on the unit keeping push button P2  pressed.

ED9 flashes for a while and the first digit appears, as in the previous paragraph. This version has 3 digits.

7. INSTALLATION

- Mount the electrolytic cell in vertical position, electrical connections up. If this is not possible, it can be mounted horizontally but the small auxiliary electrode must be up.
- Place the cell as high as possible and always after the filter.
- **A good earth connexion is imperative** and also to use a differential relay with maximum 30 mA of sensibility.
- Do not obstruct the back side of the electronic control, open air is needed to avoid overheated.
- Disconnect the power supply before any maintenance operation.
- Protect the equipment from the sun. Ambient temperature should never surpass 40°C.

7.1 HYDRAULIC CIRCUIT / CONNECTIONS

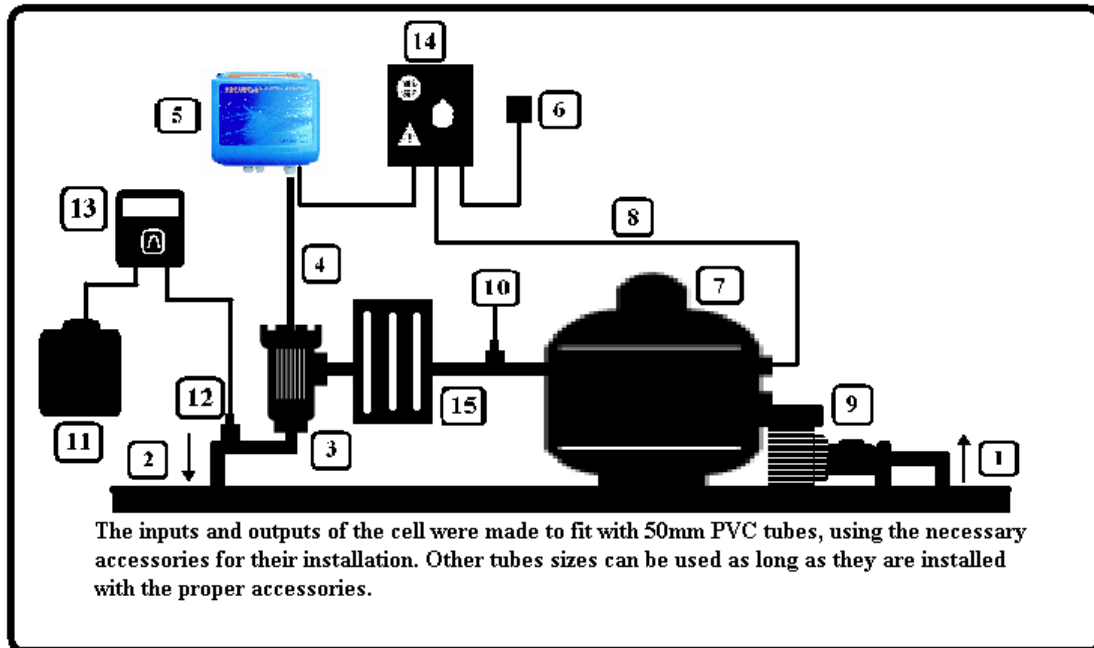

1. From swimming pool.
2. To the pool.
3. Electrolysis cell.
4. Cell cable.
5. Chlorinator CxxP
6. Power supply inlet.
7. Filter.
8. Pump cable.
9. Pump.
10. pH probe. Keep as far as possible from the cell (more than 0.5 m)
11. Acid. Keep acid far from the chlorinator. If possible, keep the acid in a separate room to avoid corrosion.
12. Acid injector.
13. pH controller
14. Pump controller
15. Water heater

7.2 WIRING DIAGRAM

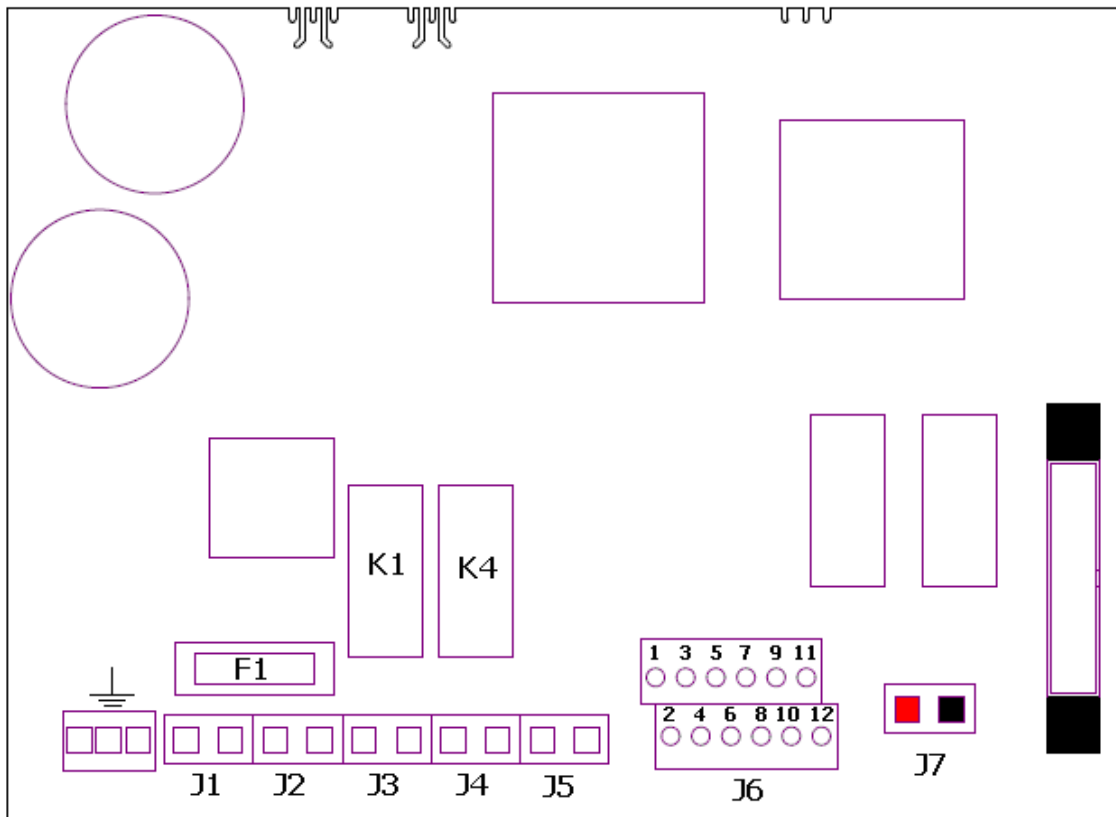

 **earth connection**

J1: Power supply 220v

J2: Switch ON/OFF

J3: Not used

J4: Not used

J5: Not used

J7: Cell connection

J6:

1- Not used

7- Not used

2- Not used

8- Not used

3- Not used

9- Not used

4- Not used

10- Not used

5- Water Sensor

11- Not used

6- Not used

12- Not used

K1: Not used

K4: Not used

F1: Fuses

8. MAINTENANCE

The chlorinator has an automatic cleaning system of the electrolytic cell which allows a minimum of maintenance. But it is advisable to clean the cell starting season.

The electrolytic cell will age with time.

If after a cleaning operation the unit does not work properly, the sensor or the cell has to be replaced. In any case your distributor will advise you on the need of a replacement.

8.1 Cleaning the electrolytic cell

Clean the cell into a solution of water with 20%of hydrochloric acid. Do not use sharp tools to clean it as they could damage the titanium surface.

The cell must be cleaned in following cases:

- If the lack of salt warning appears but the salt concentration is right.
- If the excess of salt warning appears and the salt concentration is right.
- If the lack of water flow warning appears and there is water flow in the cell.

8.2 Water chemical balance maintenance:

To set chlorine production, it is recommended to check chlorine concentration frequently, mainly during the first's days of use and increase or decrease the productions depending on its needs.

You can see below the balance values for the swimming pool water:

Parameter	Minimum	Maximum
pH	7,0	7,8
Free chlorine (mg/l)	0,5	2,5
Combined chloride (mg/l)	--	0,6
Total bromine (mg/l)	3,0	6,0
Biguanide (mg/l)	25	50
Cyanuric Acid (mg/l)	--	<75
Ozone (glass) (mg/l)	--	0
Ozone (before)	0,4	--
Water Temperature	24	30
Turbidity (NTU)	--	<1
Oxides (mg/l)	--	<3
Nitrates (mg/l)	--	<20
Ammonia (mg/l)	--	<0,3
Iron (mg/l)	--	<0,3
Copper (mg/l)	--	<1,5
Alkalinity (mg/l)	100	160
Conductivity (us/cm)	--	<1700
Tds (mg/l)	--	<1000
Hardness Calcium (mg/l)	150	250

9. WARRANTY AND SERVICE

BSV Electronic S.L. offers a two years warranty on his chlorinators for the control unit.

The electrolysis cell is warranted 2 years or 5 000 hours for any chlorinator model.

This warranty is given to the unit owner and cannot be transferred. All chlorinators are fully tested in the factory before being packed. In case of any problem during the 24 months after the sale, default units will be repaired or replaced. We cannot replace any unit if the default one is not returned.

The warranty does not cover damages caused by corrosion, humidity, excess of temperature or vibration, wrong installation, over-voltage, or any cause alien to the normal unit operation.

In case of a default, the unit has to be returned to the distributor or to the manufacturer. Transport costs are in the charge of the customer.

Unless special agreement, all repairs under warranty will be made in the factory.

BSV Electronic may modify the products and the user's manual without notice.

Thanks for choosing the salt water chlorinator for your swimming pool.

10. SPARE PIECES

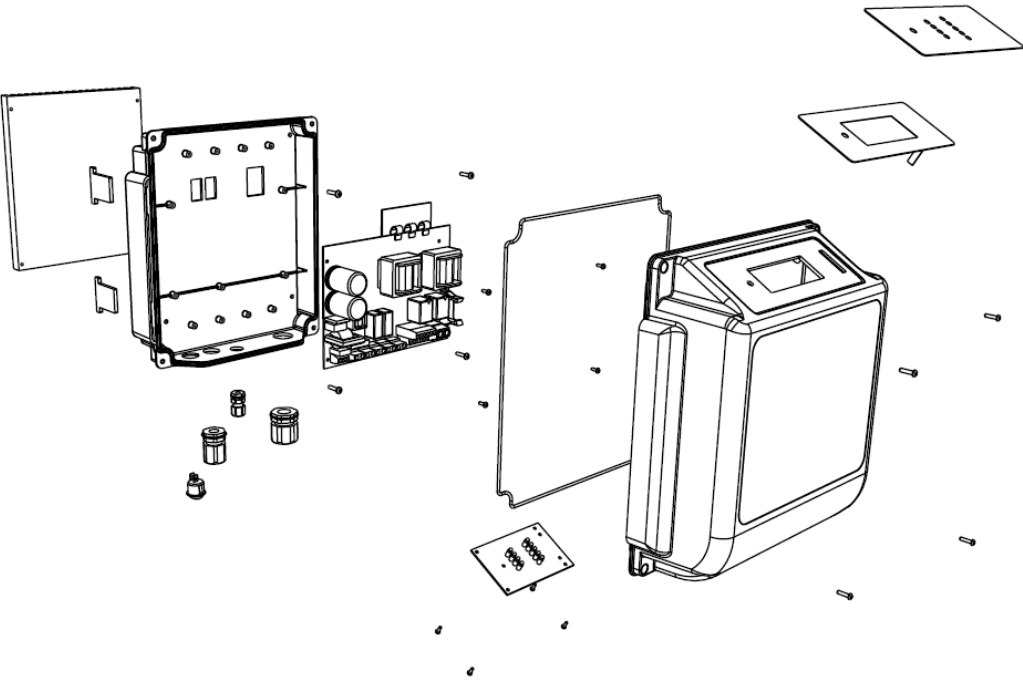
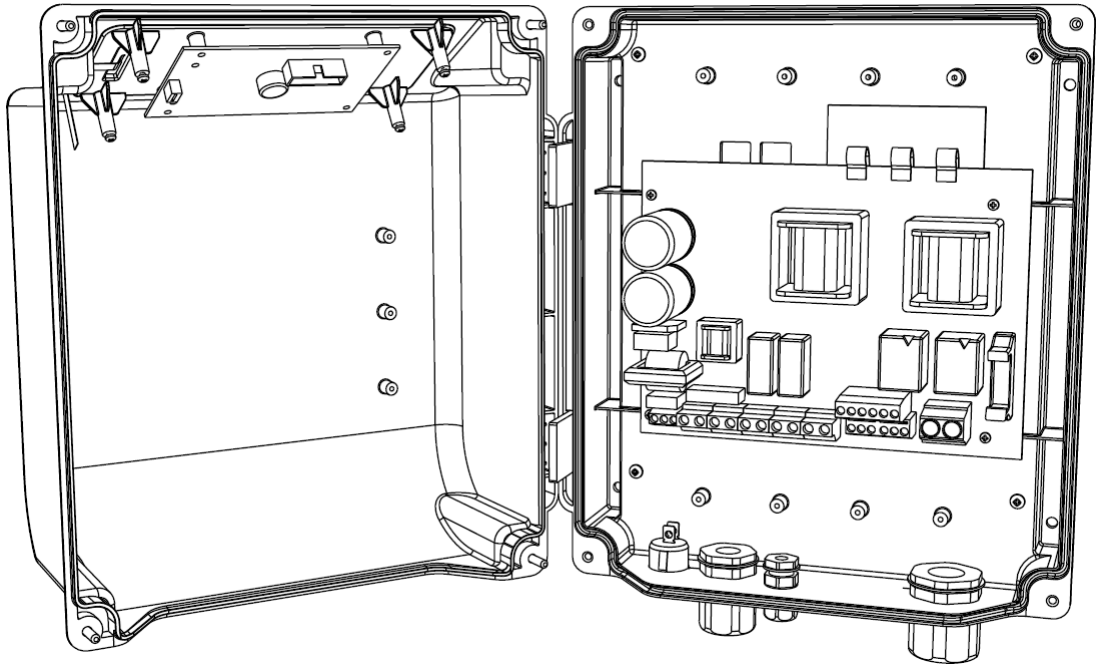

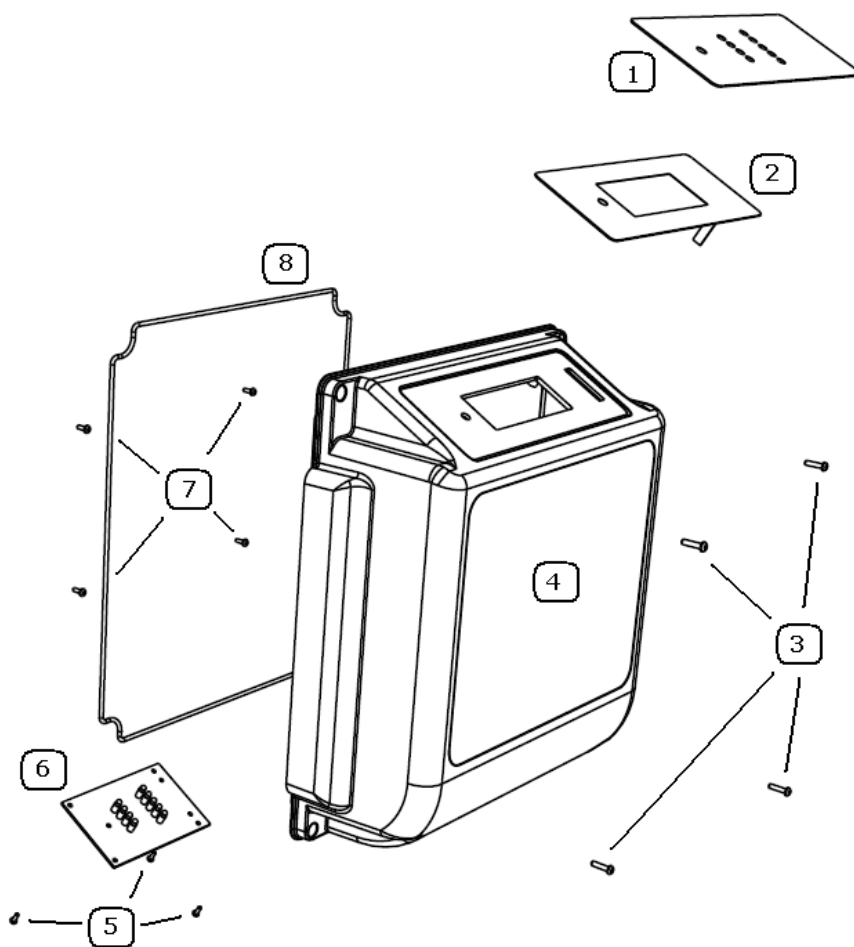

1 Keyboard cover, ref. CS-1002

2 Keyboard, ref. TECLADO-C

3 Lid's screws, ref. CL81Z x 4u.

4 Device Lid, ref. CONCEPT-TAPA

4A Lid cover, ref. CS-1001T

5 Control board fixing screws, ref. TCH2.9X9.5 x 3u.

6 Control board, ref. P909-4

7 Power board fixing screws, ref. TCH2.9X9.5 x 5u.

8 Waterproof rubber, ref. JUNTA01

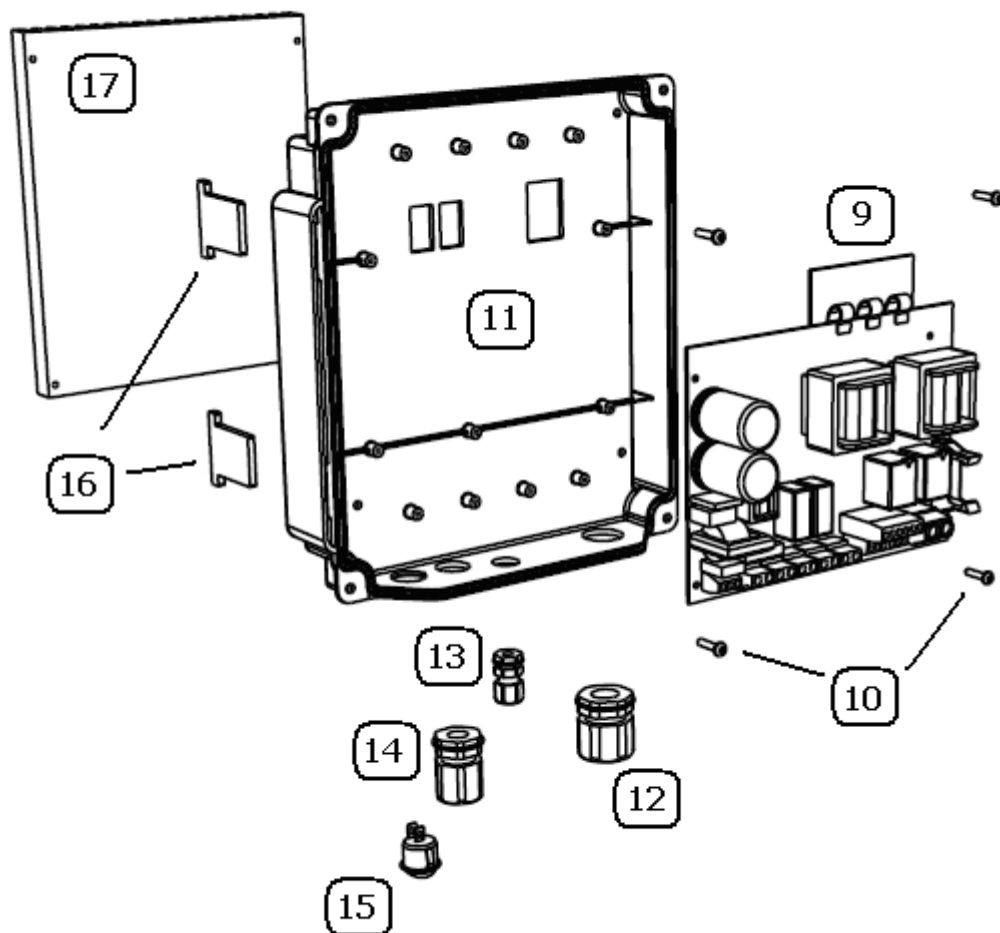

9 Power board, ref. P927

10 Radiator fixing screws, ref. TCH4.2X16 x 4u.

11 Device basis, ref. CONCEPT-BASE

12 Stuffing boxes M25, ref. M25JSL

13 Stuffing boxes M20, ref. M20JSL

14 Stuffing boxes M16, ref. M16JSL

15 Switch + protector, ref. R13112AAA + F0188LOAAA

16 Box hinge, ref. BISAGRA-GOMA x 2u.

17 Radiator Concept-P, ref. KP200/288

11. ANNEXE 1

IP65 SYSTEM:

It has the following features:

-It has a 6 protection against the dust and strange things.

Protection against the dust entrance (Dust tightness), total protection against contacts.

-It has a 5 protection against the water entrance.

Protection against water splashing from any direction.

11.1 ANNEXE 2

To take into account

The device connection strip and the cell must stick together well to avoid overheating in the contacts and to avoid the strip to burn.



12. CHARACTERISTICS

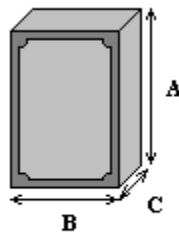

MEDIDA: A x B x C

MEASURE (mm.)	280x250x135
WEIGHT(Kg.)	4

CE DECLARATION OF CONFORMITY

Manufacturer : **BSV Electronic, S.L.**
Address : C/ Ribera del Congost, 40 A
Pol. Ind. Sector V
08520 Les Franqueses del Vallès
Barcelona (España)

Certified Products: **Salt Water Chlorinators for Swimming Pools BSPOOL**

Series: **Concept-S**

Models: **C10S, C15S, C20S, C25S, C10SK, C15SK, C20SK, C25SK, C10SPH, C15SPH, C20SPH, C25SPH, C10SPHK, C15SPHK, C20SPHK, C25SPHK**

Series: **Concept-p**

Models: **C08P, C10P, C15P, C20P, C25P**

Series: **SMART**

Models: **Sch35, Sch35pH, Sch50, Sch50pH, Sch70, Sch70pH, Sch100, Sch100pH**

Serie: **pH**

Models: **PH-P, PH-P 5L**

We declare that the above mentioned products comply with the essential protection Guidelines and Standards requirements detailed below:

European Directive to Low Tension D73/23/CEE and Modification D93/68/CEE. Equipments with supply from 50 to 1000 Vac and/or from 75 to 1500 Vdc.

Directive 99/05/CE, of the European Parliament and the Council on March 9, 1999, into the Spanish legislation under Real Decree 1890/2000, on November 20, 2000.

Insulations, pollution degrees 3	EN60950
Immunity	EN61000-6-2
Emission	EN61000-6-4 (EN 55022:2000)
Harmonics	EN61000-3-2
High frequency	EN61000-4-3
Immunity to Radiation	EN61000-4-6

Les Franqueses del Vallès, 2012

Jordi Vila i Punzano
Director General

